



**COGRI AUSTRALIA PTY LTD**  
Global Flooring Solutions

# Floor Joint Repairs

Floor joints are in fact controlled cracks in concrete slabs. They should be designed and positioned to allow the floor to move without restraining that movement. Early life drying shrinkage and long term thermal changes are the main causes of floor joint movement. CoGri's joint sealant is rigid enough to provide support and protection to the concrete arrisses, but also flexible enough to accommodate any opening of the joint and still remain bonded to at least one face of the concrete slabs.

Joints are often the greatest source of maintenance problems in industrial or warehouse floors. Their edges, or arrisses, are vulnerable to damage and tend to 'spall' under the impact from hard wheeled traffic.

Most industrial and warehouse floors will have joints with spalled edges and this should be seen as an early indication of more serious potential long term damage.

**Joint edge spalling never gets better with neglect - it always gets worse.**

Using the joint reseal detail (below) in conjunction with CoGri's semi-rigid joint sealant, we can reduce or even prevent further edge spalling. However, this relatively simple repair process can only be utilised if the edge damage is detected at an early stage. If more serious damage has already occurred we would need to re-construct the joint 'arrisses' by using the repair method overleaf.

## Joint "Reseal" Repair

### Existing Problem:

Hard wheeled traffic deflects any existing 'soft' sealant and impacts against the joint arrisses, causing 'spalling'.



### The Solution:

Damage to joint is reduced/prevented by implementation of semi-rigid joint sealant. Warehouse traffic experiences smooth transition across joint.

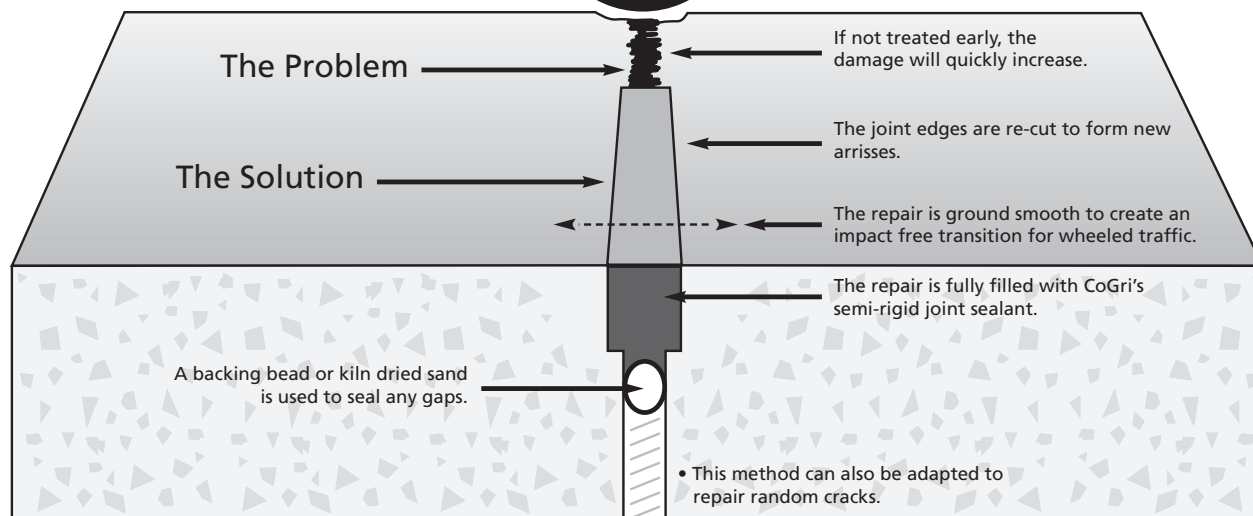

Materials Handling Equipment functions more productively on floors that are smooth and interruption free.

[www.cogriaustralia.com.au](http://www.cogriaustralia.com.au)



COGRI GROUP



**COGRI AUSTRALIA PTY LTD**  
Global Flooring Solutions

# Floor Joint Repairs

The size and cost of floor joint repairs can be kept to a minimum if the damage is detected and repaired at an early stage. Regular inspections should be made to check that the existing joint sealant is doing its job to protect and maintain the joint arrisses.

Once the damage has been allowed to progress beyond the scope of re-sealing the joint, it will be necessary to re-construct the arrisses. This should always be done with CoGri's heavy duty epoxy repair mortar that is specifically intended for industrial floor use. Cementitious materials are cheaper but they are brittle and will ultimately fail, meaning any initial saving made will be outweighed by the cost of re-repairing.

Wide joints increase the risk of arris spalling due to the deflection of the joint sealant under load. It is therefore important to reduce the width of the joint opening at surface level. Our tried and tested joint arris repair detail (shown below) allows a 50mm wide 'traditional expansion joint' to be replaced with a neat 5mm wide, fully sealed saw cut. Each of our repairs are ground smooth and flush with the adjacent floor surface to ensure that wheeled traffic has a smooth transition over the repaired joint.

Our repair processes have been specifically developed for use in operational, fully stocked warehouses. We use highly efficient vacuum systems to ensure that there will be no airborne dust created, so there is no need to remove or protect your stock.

## Joint "Arris" Repair

### Existing Problem:

Hard wheels and heavy impact loads from materials handling equipment cause major damage to the joint arrisses.



### The Solution:

New extremely durable joint system provides a smooth surface on which warehouse traffic can pass, potentially reducing maintenance costs to MHE.

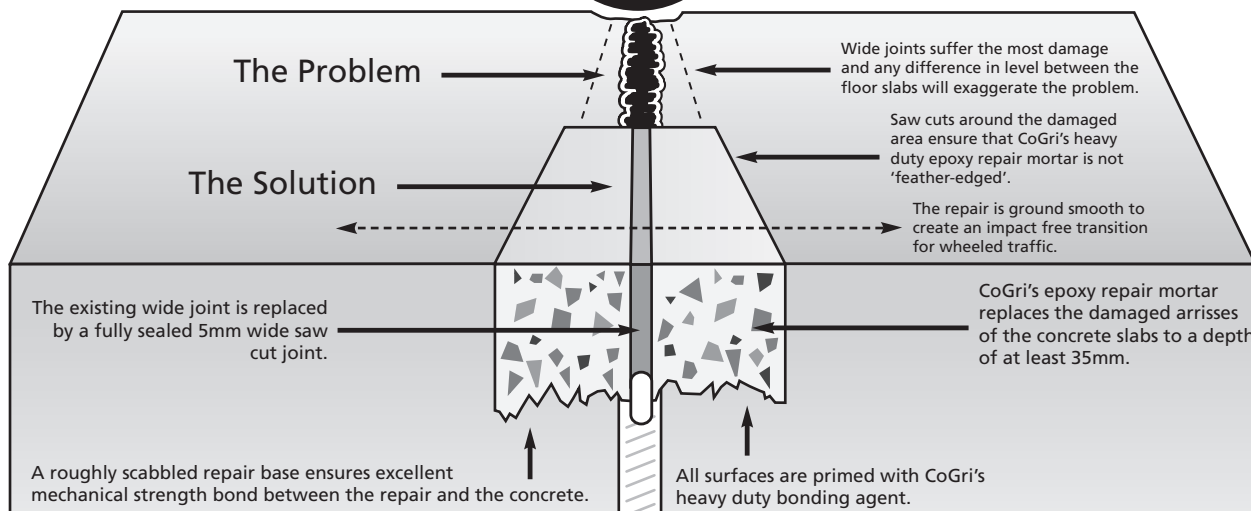

Well maintained floor joints help to reduce the cost of servicing & maintaining your MHE.

**To arrange a site visit, call the experts...**

CoGri Australia Pty Ltd, Suite 101, 410 Elizabeth Street, Surry Hills, NSW 2010, Australia

Tel: +61 1300 802 558 Email: [info@cogriaustralia.com.au](mailto:info@cogriaustralia.com.au)

Website: [www.cogriaustralia.com.au](http://www.cogriaustralia.com.au)



COGRI GROUP